

Catheter Valves

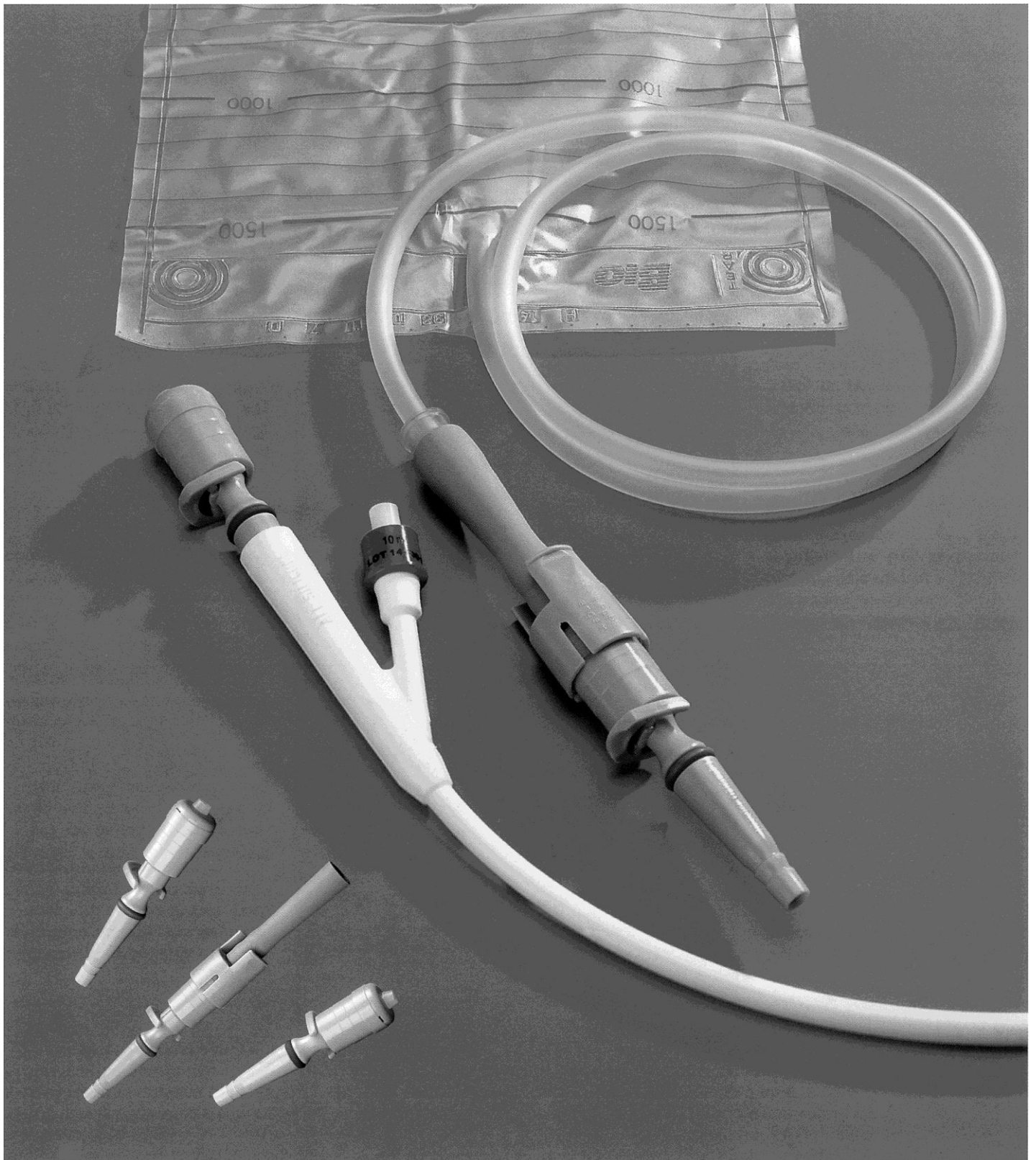

Válvulas do cateter



The alternative to carrying a urine bag

Urine drain valves recommended by physicians

- Reduces the risk of contamination many times over compared to catheter plugs.
- Forms a closed system together with the indwelling catheter.
- Allows bladder emptying in a natural rhythm.
- Counteracts the loss of bladder capacity.
- With precise opening and closing mechanism.
→ Makes every micturition more hygienic.
- Is simple to clean.
- Catheter valves are made of polyamide, spring steel and silicone.
- They are delivered individually packaged and sterilized
- Sterilization process: Ethylene oxide (EO).
- Sterilization warranty:
With undamaged packaging and proper storage: 5 years.



Do not reuse

Catheter valve KV 100

with bayonet lock
(for two-handed operation)

Possibility of overnight connection of the urine bag with the coupling piece

REF 300000ST

green O-ring
Weight 10 g

KV 100

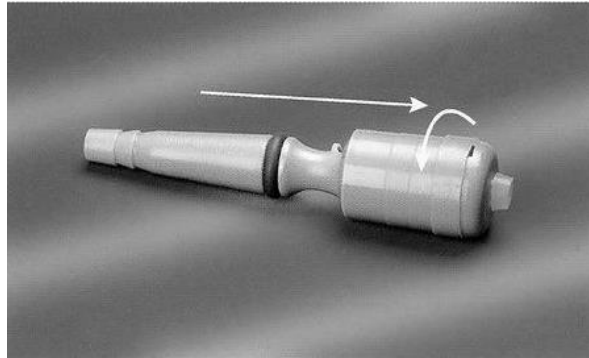

Válvula do cateter KV 100

com trava de baioneta
(operação com duas mãos)

É possível conectar a bolsa de urina durante a noite com a peça de acoplamento

REF 300000ST

anel verde
Peso 10 g

Catheter valve KV 100 EH

with trigger for one-handed operation
and automatic closure mechanism

Urine bag connection not possible

REF 300100ST

red O-ring
Weight 10.5 g

KV 100 EH

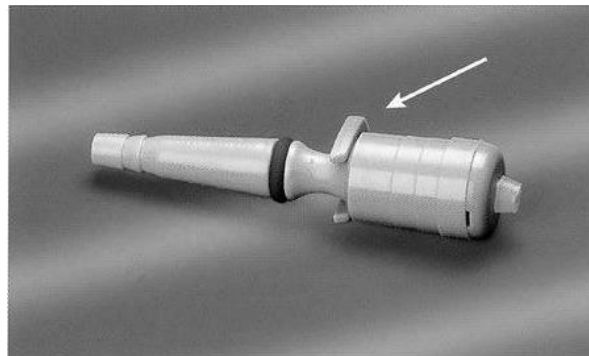

Válvula do cateter KV 100 EH

com alça para operação com uma mão
e dispositivo de travamento automático

Não é possível conectar a bolsa de urina

REF 300100ST

anel vermelho
Peso 10.5 g

Catheter valve KV 200 EH

with trigger for one-handed operation,
automatic closure mechanism and bayonet lock.

Possibility of overnight connection of the urine bag with the coupling piece

REF 300101ST

green O-ring
Weight 10.5 g

KV 200 EH

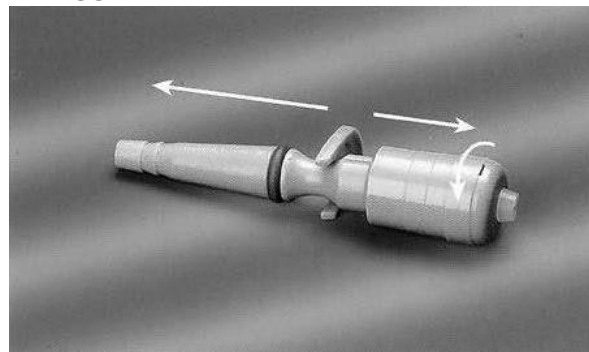

Válvula do cateter KV 200 EH

com alça para operação com uma mão,
dispositivo de travamento automático e trava de baioneta

É possível conectar a bolsa de urina durante a noite com a peça de acoplamento

REF 300101ST

anel verde
Peso 10.5 g

Possibility to connect a urine bag

Prevent multiple trips to the toilet during the night

All catheter valves with a **green** O-ring (KV 100, KV 200 EH) can be connected to a **urine bag together with the KP 200 coupling piece**.

Catheter valve KV 200 EH and coupling piece KP 200 delivered as a set
For one-hand operation and connection of urine bag

REF 300102ST

green O-ring
Weight 17 g

KV 200 EHKP

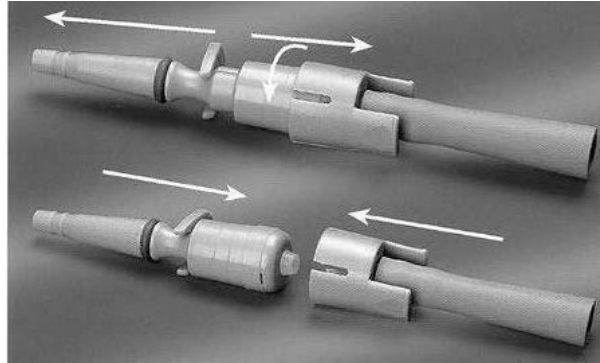

Válvula do cateter KV 200 EH e peça de acoplamento KP 200 fornecido em um conjunto para operação com uma mão e conexão da bolsa de urina

REF 300102ST

anel verde
Peso 17 g

Coupling Piece KP 200 to connect a urine bag to catheter valves KV 100 and KV 200 EH

REF 300200ST

Weight 6.5 g

KP 200

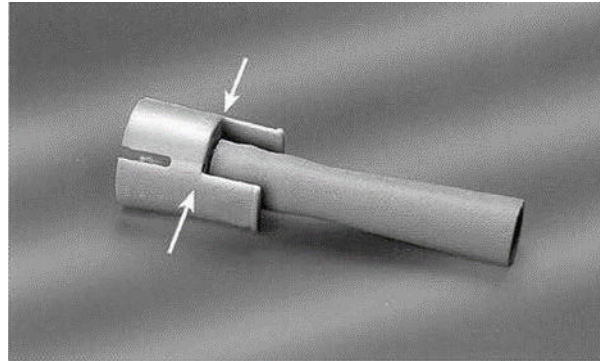

Peça de acoplamento KP 200 para conexão da bolsa de urina para as válvulas do cateter KV 100 y KV 200 EH

REF 300200ST

Peso 6.5 g

Accessories

Catheter plug

REF ST50016



Acessórios

Plugue do cateter

REF ST50016

Catheter clamp

REF ST50015



Abraçadeira do cateter

REF ST50015

We will be happy to send you detailed documentation
Your specialized dealer

Teremos prazer em lhe enviar a documentação detalhada.
Seu revendedor especializado